



Camera and Electronic Products for Integrators

AutoVIEW™ StepVIEW™

Presenter's Camera Location System

Vaddio's StepVIEW Presenter Camera Location System provides for automated presenter control over the Vaddio ControlVIEW Xtreme Pan/Tilt/Zoom Camera Control System.



StepVIEW Exposed Mat



StepVIEW Concealed Mat

INTRODUCTION

The StepVIEW system works by having the presenter step on the heavy duty, presence sensing, and non-slip auto locator mats in the area that the cameras are to be used. Camera presets are assigned to those mat locations and programmed into the ControlVIEW Extreme. As the presenter walks to different areas in the room (i.e. behind the lectern, up to the whiteboard, etc...) the mats trigger the AutoVIEW Control Expander, which in turn commands the cameras to move to that area of the room automatically.

The StepVIEW presence sensing mats come in both a rubberized, non-slip exposed auto-locator mat and an architectural thin, concealed auto-locator mat for permanent installation underneath carpeting or rolled flooring products (see pictures at the top of the page). The StepVIEW trigger mats are durable, attractive and come in two different sizes for flexibility of mat positioning.

The StepVIEW system is the perfect addition to the Vaddio ControlVIEW Xtreme Pan/Tilt/Zoom Camera Control System when used in a hands-free, presenter controlled camera-switching conferencing environment.

INTENDED USE

Before installing and operating the Vaddio StepVIEW System, please read the entire manual thoroughly. The system was designed, built and tested for use indoors, and with the provided power supply and cabling. The use of a power supply other than the one provided or outdoor operation has not been tested and could damage the system and/or create a potentially unsafe operating condition.

**IMPORTANT
SAFEGAURDS**



Read and understand all instructions before using. Do not operate these products if they have been have been dropped or damaged. In this case, a Vaddio technician must examine the product before operating. To reduce the risk of electric shock, do not immerse in water or other liquids and avoid extremely humid conditions.

Use only the power supply provided with the StepVIEW Camera Location System. Use of any unauthorized power supply will void any and all warranties.

UNPACKING

Carefully remove the products and all of the parts from the packaging. Unpack and identify the following parts (see Figure 1):

For StepVIEW with Exposed Mats - Part Number 999-1500-000

- One (1) AutoVIEW Control Expander
 - PowerRite™ Power Supply and cable
 - Rack Mount Ears for AutoVIEW
- Two (2) Small Exposed Presence-sensing automatic locator mats
 - 44" x 27.5" (1.12m x 70cm) with attached 75' (22.9m) cable
- One (1) Large Exposed Presence-sensing automatic locator mat
 - 57" x 27.5 (1.45m x 70cm) with attached 75' (22.9m) cable
- Three (3) StepVIEW Interface Controllers
- Three (3) - 2-Pin Phoenix type connectors
- Three (3) - 3' (.91m) Category 5 patch cables
- Installation and User Guide (341-198)

StepVIEW with Concealed Mats - Part Number 999-1600-000

- One (1) AutoVIEW Control Expander
 - PowerRite™ Power Supply and cable
 - Rack Mount Ears for AutoVIEW
- Two (2) Small Concealed, presence-sensing automatic locator mats
 - 45" x 21" (1.14m x 53cm) with attached 75' (22.9m) cable
- One (1) Large Concealed, presence-sensing automatic locator mat
 - 56" x 21" (1.42m x 53cm) with attached 75' (22.9m) cable
- Three (3) StepVIEW Interface Controllers
- Three (3) - 2-Pin Phoenix type connectors
- Three (3) - 3' (.91m) Category 5 patch cables
- Installation and User Guide (341-198)

Figure 1: Vaddio AutoVIEW StepVIEW System Components (Exposed mats shown)

- AutoVIEW Control Expander
- Two (2) Small Mats
- One (1) Large Mat
- Three (3) Interface Controllers
- Three (3) Cat 5 cables
- One (1) Power Supply

- Not Shown:
- One (1) Pair rack ears
 - Three (3) 2-Pin Phoenix connectors

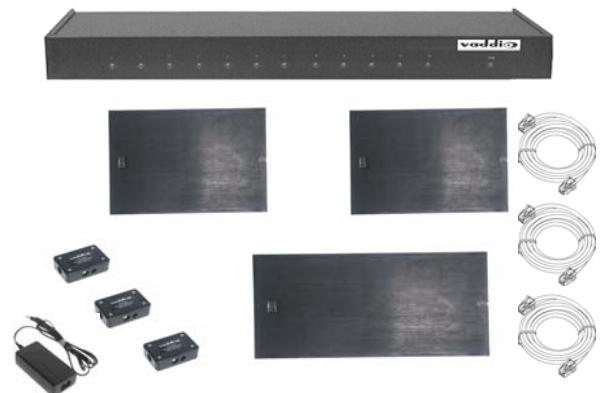

INSTALLATION

Mats

Installation of the AutoVIEW StepVIEW Presenter controller is as unique as it is simple. With any Vaddio product, understanding the key system components is essential.

All of the mats (exposed or concealed) are presence sensing and feature an attached 75' (22.9m) cable. This cable can be used as is or shortened to accommodate smaller rooms. Lay out the mats where intended for use and run the attached cable to the control equipment area.

The exposed mats feature a non-slip surface and beveled or angled edge for comfort and convenience. The concealed mats are thin and are meant for installation under rolled flooring products. The exposed mat edge profile is shown below (see Figure 2).

Figure 2: Exposed Mat edge profile and dimensions

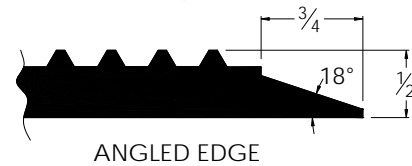

Do Not try to permanently mount the mat by piercing the mat surface with any type of fasteners. Piercing the mat will cause the mat to fail and void any and all warranties.

Connection

The attached cable is terminated to the StepVIEW Interface Controller (see Figure 3) with the supplied 2-pin Phoenix type connector (see Figure 4). When connecting the mat wires to the Phoenix connector, be sure that the bare wires are not exposed or false triggers may result.

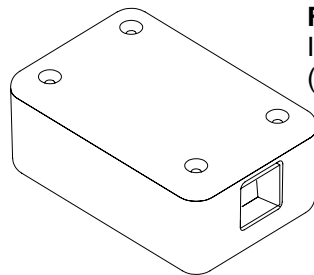

Figure 3: StepVIEW Interface Controller box (isometric view)

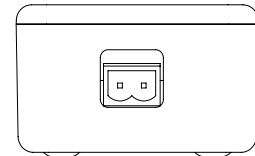
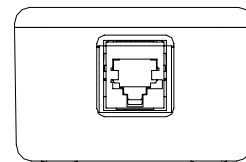

Figure 4: StepVIEW Interface Controller box (end view) 2-pin connector shown

The RJ-45 jack on the StepVIEW Interface Controller is then connected to the AutoVIEW control expander using the supplied 3' (.91m) Cat. 5 patch cables.

Figure 4: StepVIEW Interface Controller box (end view) RJ-45 jack shown



Power is supplied to the StepVIEW Interface Controller and mat by the RJ-45 connection on the AutoVIEW Control Expander.

**INSTALLATION
(continued)**

The front panel of the AutoVIEW Control Expander features twelve 12 AutoVIEW LED activation LEDs that will pulse on and off when the mat is stepped on and presence is detected. The pulse is created by the StepVIEW Interface Controller and is required in order to give another trigger priority (i.e. mic switch and gate activation on MicVIEW Microphone Switcher/Mixer) over the mat.

Important Note: Mats have equal switching priority and only one mat can be activated at a time. Activating two mats concurrently will cause undesirable camera switching (in one second intervals) between the mat locations.

The front panel and back panel diagrams and a quick connection diagram for a single mat are shown below (see Figure 5). For Other AutoVIEW Switching applications, please see the manual for the AutoVIEW Control Expander (formerly the ControlVIEW Control Expander)

Figure 5: Front and back panel Diagrams of AutoVIEW Control Expander

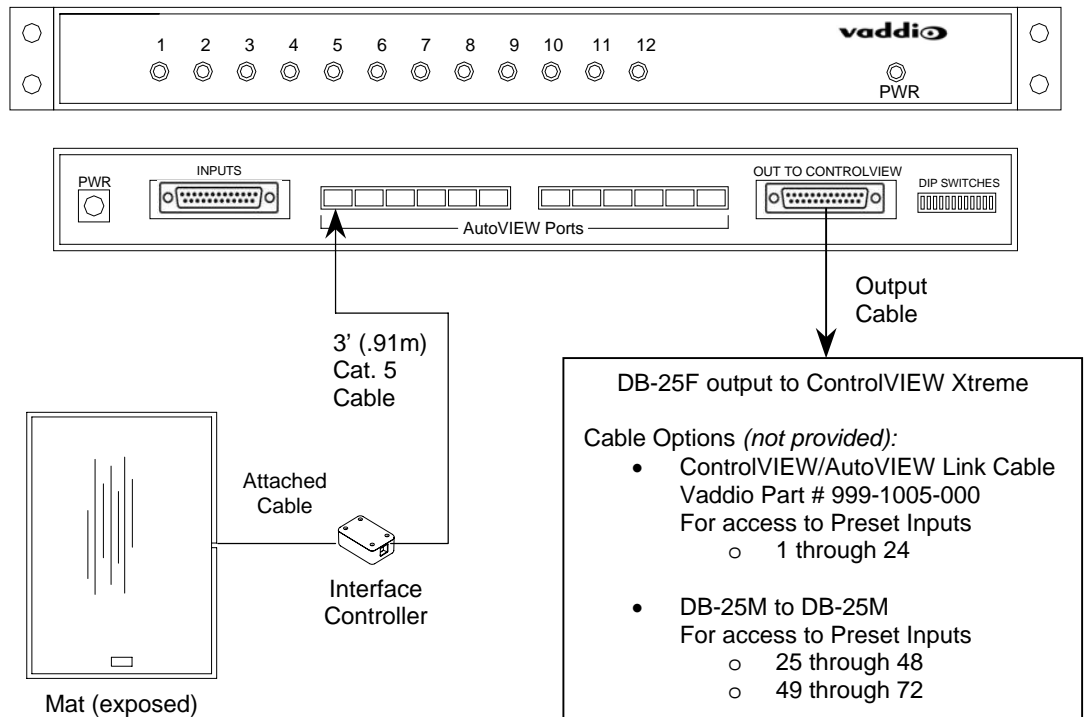

Setting Dip Switches

Set LED Dip Switches for each mat used on the back of the AutoVIEW Control Expander for the corresponding port number to the “ON” or up position (i.e., DIP Switch 1 controls Input 1) see Figure 6.

Figure 5: Dip Switches should be in “UP” position for each mat used



**DB-25
Pin-Outs for
Output Cable to
ControlVIEW
Xtreme**

Table 1: DB-25 Output Pin-outs



Each of the first 12 output pins corresponds directly with the number on the AutoVIEW Port (12 output contacts = 12 AutoVIEW Ports. Pins 13 and 25 are not used.

Pin	Pin Function
1	Preset 1
2	Preset 2
3	Preset 3
4	Preset 4
5	Preset 5
6	Preset 6
7	Preset 7
8	Preset 8
9	Preset 9
10	Preset 10
11	Preset 11
12	Preset 12
13	NOT USED
14	Ground
15	Ground
16	Ground
17	Ground
18	Ground
19	Ground
20	Ground
21	Ground
22	Ground
23	Ground
24	Ground
25	NOT USED

**Cabling
Notes**

Each StepVIEW mat has an attached 75' (22.9m) 2-conductor cable. This cable is for use in exposed wire applications only. If in-wall and in-ceiling cabling is required, please splice in the necessary "plenum rated" 2-conductor wire (18AWG recommended).

**CARE AND
CLEANING**

Do not attempt to take the products in this system apart. There are no user-serviceable components inside.

- Do not spill liquids on the products
- Keep these devices away from food and liquid
- For smears or smudges on the mat, clear with a clean, soft cloth. Do not use any abrasive chemicals.

**OPERATING
AND STORAGE
CONDITIONS**

Do not store or operate the AutoVIEW StepVIEW System under the following conditions for any circumstance:

- Temperatures above 40°C (104°F)
- Temperatures below 0°C (32°F)
- High humidity, condensing or wet environments
- Dusty environments
- In inclement weather
- Under severe vibration

**SYSTEM
CONFIGURATIONS
North America**

For StepVIEW with Exposed Mats - Part Number 999-1500-000

- One (1) AutoVIEW Control Expander
 - PowerRite™ Power Supply and North American cable
 - Rack Mount Ears for AutoVIEW
- Two (2) Small Exposed Presence-sensing automatic locator mats
 - 44" x 27.5" (1.12m x 70cm) with attached 75' (22.9m) cable
- One (1) Large Exposed Presence-sensing automatic locator mat
 - 57" x 27.5 (1.45m x 70cm) with attached 75' (22.9m) cable
- Three (3) StepVIEW Interface Controllers
- Three (3) - 2-Pin Phoenix type connectors
- Three (3) - 3' (.91m) Category 5 patch cables
- Installation and User Guide (341-198)

StepVIEW with Concealed Mats - Part Number 999-1600-000

- One (1) AutoVIEW Control Expander
 - PowerRite™ Power Supply and North American cable
 - Rack Mount Ears for AutoVIEW
- Two (2) Small Concealed, presence-sensing automatic locator mats
 - 45" x 21" (1.14m x 53cm) with attached 75' (22.9m) cable
- One (1) Large Concealed, presence-sensing automatic locator mat
 - 56" x 21" (1.42m x 53cm) with attached 75' (22.9m) cable
- Three (3) StepVIEW Interface Controllers
- Three (3) - 2-Pin Phoenix type connectors
- Three (3) - 3' (.91m) Category 5 patch cables
- Installation and User Guide (341-198)

**SYSTEM
CONFIGURATIONS
International**

For StepVIEW with Exposed Mats - Part Number 999-1500-001

- One (1) AutoVIEW Control Expander
 - PowerRite™ Power Supply and Euro/UK cable
 - Rack Mount Ears for AutoVIEW
- Two (2) Small Exposed Presence-sensing automatic locator mats
 - 44" x 27.5" (1.12m x 70cm) with attached 75' (22.9m) cable
- One (1) Large Exposed Presence-sensing automatic locator mat
 - 57" x 27.5 (1.45m x 70cm) with attached 75' (22.9m) cable
- Three (3) StepVIEW Interface Controllers
- Three (3) - 2-Pin Phoenix type connectors
- Three (3) - 3' (.91m) Category 5 patch cables
- Installation and User Guide (341-198)

StepVIEW with Concealed Mats - Part Number 999-1600-001

- One (1) AutoVIEW Control Expander
 - PowerRite™ Power Supply and Euro/UK cable
 - Rack Mount Ears for AutoVIEW
- Two (2) Small Concealed, presence-sensing automatic locator mats
 - 45" x 21" (1.14m x 53cm) with attached 75' (22.9m) cable
- One (1) Large Concealed, presence-sensing automatic locator mat
 - 56" x 21" (1.42m x 53cm) with attached 75' (22.9m) cable
- Three (3) StepVIEW Interface Controllers
- Three (3) - 2-Pin Phoenix type connectors
- Three (3) - 3' (.91m) Category 5 patch cables
- Installation and User Guide (341-198)



WARRANTY INFORMATION

Hardware* Warranty - One year limited warranty on all parts. Vaddio warrants this product against defects in materials and workmanship for a period of one year from the day of purchase if Vaddio receives notice of such defects during the warranty. They will, at its option, repair or replace products that prove to be defective.

Exclusions - The above warranty shall not apply to defects resulting from: improper or inadequate maintenance by the customer, customers applied software or interfacing, unauthorized modifications or misuse, operation outside the normal environmental specifications for the product, use of the incorrect power supply, or improper site operation and maintenance.

Vaddio Customer service – Vaddio will test, repair, or replace the product or products without charge if the unit is under warranty. If the product is out of warranty, Vaddio will test then repair the product or products. The cost of parts and labor charge will be estimated by a technician and confirmed by the customer prior to repair. All components must be returned for testing as a complete unit. Vaddio will not accept responsibility for shipment after it has left the premises.

Return Material Authorization (RMA) number - Before returning a product for repair or replacement request an RMA from Vaddio's technical support. Provide a technician with a return phone number, e-mail address, shipping address, and product serial numbers. Describe the reason for repairs or returns as well as the date of purchase. Include your assigned RMA number in all correspondence with Vaddio. Write your assigned RMA number on the outside of the box when returning the product.

Voided warranty – The warranty does not apply if the original serial number has been removed or if the product has been disassembled or damaged through misuse, accident, modifications, or unauthorized repair.

Shipping and handling - Vaddio will not pay for inbound shipping transportation or insurance charges or accept any responsibility for laws and ordinances from inbound transit. Vaddio will pay for outbound shipping, transportation, and insurance charges all items under warranty but will not assume responsibility for loss and/or damage by the outbound freight carrier.

- If the return shipment appears damaged, retain the original boxes and packing material for inspection by the carrier.
 - Contact your carrier immediately.

Products not under warranty - Payment arrangements are required before outbound shipment for all out of warranty products.

*Vaddio manufactures its hardware products from parts and components that are new or equivalent to new in accordance with industry standard practices.